

Installation Manual and Guide for Tanks „OPTI-Betholit“

Dear Customer,

Congratulations on your decision to purchase our Rainwater Products. In the choice of material and during the production process we gave special attention to ensure long term functionality.

To ensure, that you have a long enjoyment with this product, please study the Installation Manual carefully.

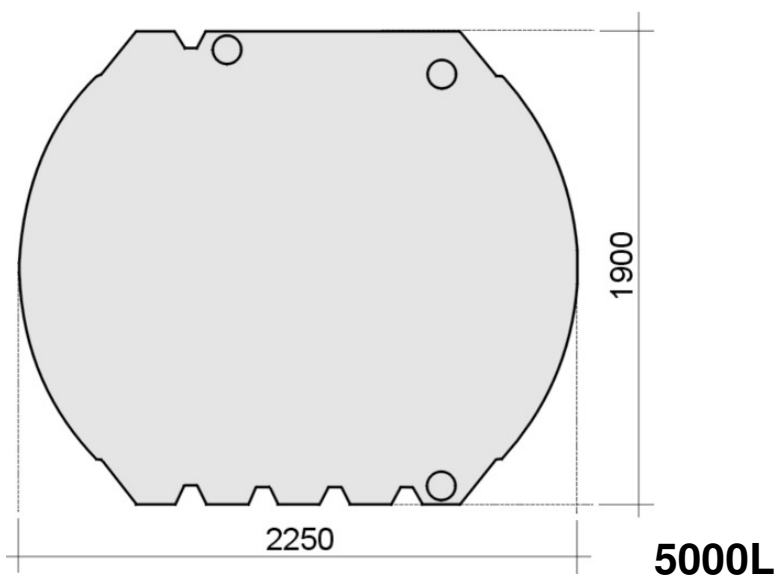
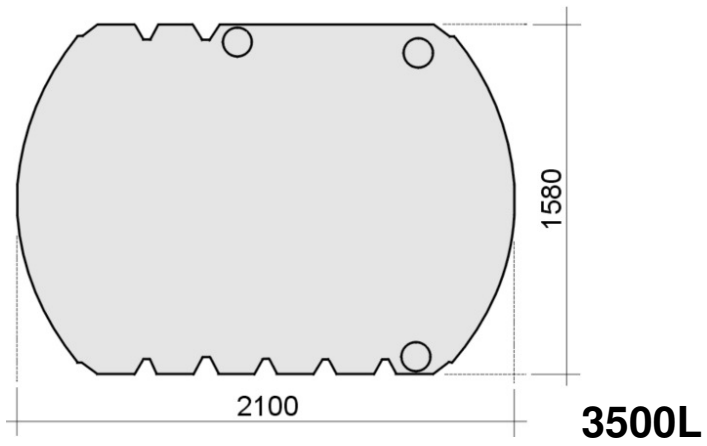
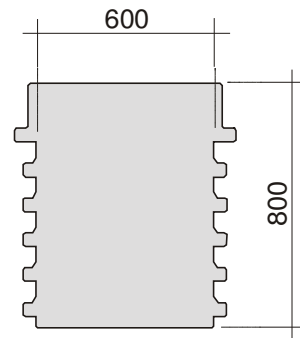
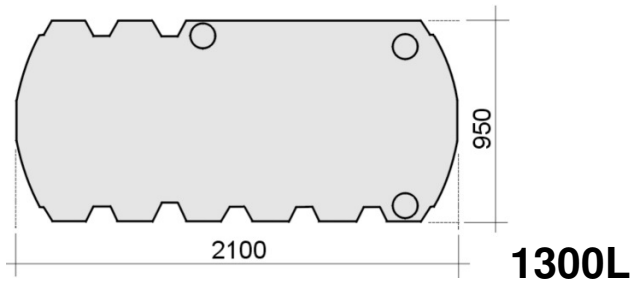

General..

Before installation of the tank please check the ground situation, i.e. ground water level. Please make sure, the trench is secured and the walls can not collapse. The 1300L tank can be used under- or overground. The 3500L- and 5000L- tanks are suitable for underground installation (max. burial depth 80cm.) With underground installation a vertical shaft extension is usually required. If installed overground, the tanks should be emptied during frost periods.

If required, please be sure to order vertical shaft extensions before tank installation to ensure problem-free attachment and to receive it in the right time.

To ensure that even after a number of years a mistake in connecting drinking water with used water occurs, all pipes with rainwater should have a label or pictogram “No Drinking Water”-“Kein Trinkwasser”. For this you can use our set Nr Z-KSU.



1 Tank Installation

1.1 Installation Steps

- Dig Trench and remove stones
- Compress trench ground
- Layout sand bed (20cm-depth) on trench ground level and compress
- Place tank and shake manually
- Connect filter and connections
- Clean inside of tank
- Half fill the tank with water
- Fill trench with sand to half shoulder height of the tank
- Completely fill tank with water
- Fill trench with sand to shoulder height of the tank
- Attach connections
- Fill trench to appx 15cm below vertical shaft lid
- For the rest height sand could be mixed together with flower earth

1.2 Trench

Please note that a maximal burial depth of 80cm is allowed, when digging trench. Leave enough space between the tank and the trench walls appx 30-60cm. The depth of the trench depends on the height of the tank used (if required with shaft extension) and the sand bed (20cm). The lid of the tank should be app. 10-15cm above the ground to ensure no dirt falls into the tank when opening lid. Depending on tank position please ensure a 1-2 % down gradient for the inflow pipe. Make sure that the ground can carry the weight of the tank and is clear of stones, sharp objects (glass, metals, etc.) and is compressed.

1.3 Positioning the Tank

If a vertical shaft extension is needed please use only original Regen-Tec parts. Lower the tank carefully in the trench and position it horizontally on the sand bed. Before filling the tank with water make all required connections. The 1300L tank can be used under- or overground. The 3500L and 5000L tanks are suitable for underground installation (max. burial depth 80cm.) With underground installation a vertical shaft extension is usually required. Half fill the tank with water and fill the trench with sand to the water level. Compress manually. Now connect inflow and drainage pipes and completely fill the tank with water and then fill the trench with sand as described.

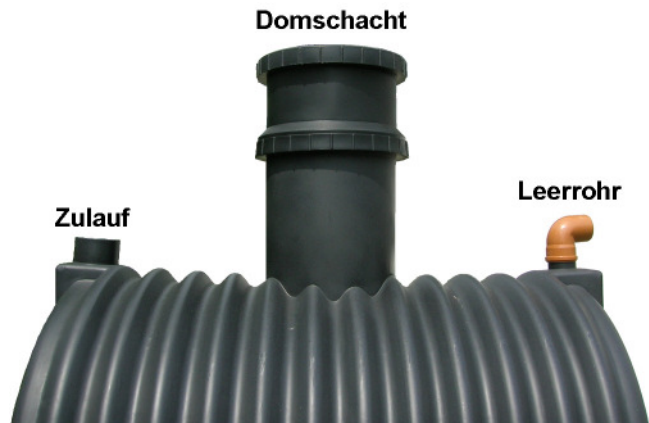

Important: Compress Manually! Before use please clean tank carefully!

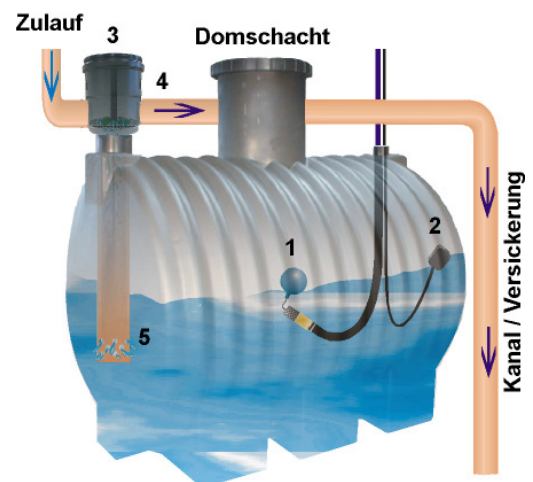

1. Floating inlet
(water output pick up)
2. Floating Switch
(please fix at desired level
app. 15cm above ground))
3. Earth Filter (E150-CS1)
4. Overflow on Filter to
5. Filter E 150-CS1
(calmed inlet)

1.4 Connecting multiple tanks underground

For connecting tanks underground a connection kit (Z-VST) is available. Please cover it with a protecting pipe.

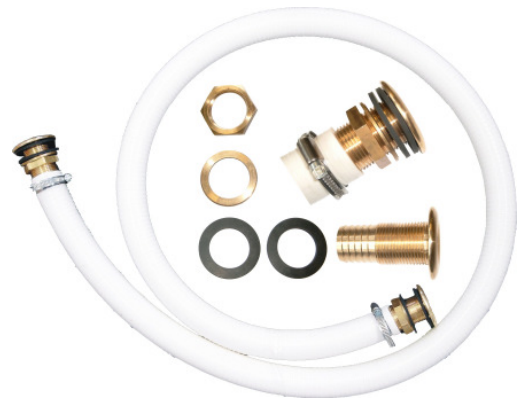

2. Installation in special circumstances

2.1 Installation in vehicle access area (e.g. garage entrance)

Should the tank be installed in a vehicle access area, the installation must be done to include a reinforced concrete sheath around the tank. Please consult an expert on this matter. The concrete should be poured layer for layer otherwise the life span of the tank will be reduced because of permanent pressure. Please also be sure to include a vehicle access vertical shaft lid (consult your expert). The vehicle access can also be achieved, if a load bearing concrete slab is laid to take the weight load of the tank.

2.2 Installation in an area with a high groundwater level

Should the tank be installed in an area with high groundwater level or flood threat areas, the tank has to be secured accordingly against floating and deformation. Please consult your expert on this matter.

2.3 Installation in an area with slope

If the tanks is to be installed in an area (closer than 5m) with a slope the side pressure from the slope against the tank should be compensated with a wall. Please consult your expert on this matter.

2.4 Installation in an area with earth water leakage

In such an area the fill sand has to be secured against washing away by using a geo-textile material between the earth and the fill sand. Please consult your expert on this matter.

2.5 Installation in an area with heavy ground (like)

Please consult your expert on this matter.